

INTERNATIONAL JOURNAL OF ENGINEERING SCIENCES & MANAGEMENT

**Synchronization & Control of Grid Connected Inverter for
Standalone Power Supply System**

Abhimanyu Kumar¹, Vikas Mohan²

¹ME Scholar

Department of Electrical Engineering
IES College of Technology, Bhopal, MP (India),

²Assistant Professor

Department of Electrical Engineering
IES College of Technology, Bhopal, MP (India),

Abstract:

Solar, wind and hydro are renewable energy sources that are seen as reliable alternatives to conventional energy sources such as oil or natural gas. However, the efficiency and the performance of renewable energy systems are still under development. Consequently, the control structures of the grid-connected inverter as an important section for energy conversion and transmission should be improved to meet the requirements for grid interconnection. In this paper, a comprehensive simulation and implementation of a three-phase grid-connected inverter is presented. The control structure of the grid-side inverter is firstly discussed. Secondly, the space vector modulation SVM is presented. Thirdly, the synchronization for grid-connected inverters is discussed. Finally, the simulation of the grid-connected inverter system using PSIM simulation package and the system implementation are presented to illustrate concepts and compare their results.

Keywords: SVM, PSIM, SAPS.

Introduction

The increasing demand for conventional energy sources like coal, natural gas and oil is forcing people towards the research and development of renewable energy sources or non-conventional energy sources. Many renewable energy sources like wind, solar etc are now well developed, cost effective and largely used. These energy sources are environment friendly. Hybrid energy system is the combination of two or more renewable energy sources like wind, solar, hydro etc .These provide a clean and eco-friendly energy. These hybrid systems can be standalone or can be grid connected. The grid connected hybrid system are more reliable to deliver continuous power to the grid because if there is any shortage of power or fault in the renewable energy sources then the loads are directly connected to the grid. The hybrid power system consist of two Renewable energy sources which are solar energy and wind energy that are used as a input sources . A wind turbine converts mechanical energy into electrical energy and it produces ac output voltage and this ac output voltage is converted to dc by the help of ac to dc converter or rectifier. A PV cell converts the light energy into electrical energy and produces dc output voltage. The reliability to deliver continuous supply to load is more for grid connected hybrid wind and PV system. if there occurs any problem with the energy sources then the loads are connected to the grid. The main objective of this paper is to model a grid connected Solar and Wind hybrid power system. In this model, outputs of these two sources are determined. The

input for these two sources is solar radiation and wind speed. The modeling of both PV system and wind is done. The analysis of the output of system is made.

PHOTOVOLTAIC SYSTEMS

PV Equivalent Electrical Circuit Model In the crystalline silicon PV module; the complex physics of the PV cell can be represented by the equivalent electrical circuit shown in Figure 1. For that equivalent circuit a set of equations have been derived, based on standard theory, that allow the operation of a single solar cell, to be simulated using data from manufacturers or field experiments.

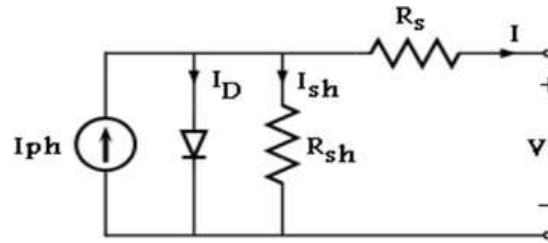

Figure 1. PV cell equivalent circuit

The circuit parameters are as follows:

The output-terminal current I equals to the light-generated current I_L , less the diode-current I_d and the shunt-leakage current I_{sh} .

– The series resistance R_s – represents the internal resistance to the current flow, and depends on the p-n junction depth, the impurities and the contact resistance. The shunt resistance R_{sh} is inversely related with leakage current to the ground

.– In an ideal PV cell, $R_s = 0$ (no series loss), and $R_{sh} = \infty$ (no leakage to ground). In a typical high quality one square inch silicon cell, $R_s = 0.05$ to 0.10 ohm and $R_{sh} = 200$ to 300 ohms.

The PV conversion efficiency is sensitive to small variations in R_s , but is insensitive to variations in R_{sh} Therefore, we can ignore R_{sh} from the equivalent electrical circuit for our modeling.

Mathematical modeling of the PV system

The equivalent circuit, the current delivered to the external load equals the current I_L generated by the illumination, less the diode current I_d and the ground-shunt current I_{sh} . The load current is given by the expression:

$$I = I_L - I_d - V_0 / R_{sh} \dots\dots\dots (1)$$

The cell could be represented by a voltage-current Eq as follow

$$V = V_0 - R_s I$$

Where:

$V_0 = V_{sh}$ = voltage on the diode and the shunt resistance

I_d = diode Current (A).

V = cell output voltage (V).

I = load (cell) output current (A).

I_L = Photocurrent (A).

I_0 = Reverse diode saturation current (A).

The two most important parameters widely used for describing the cell electrical performance are the open-circuit voltage V_{oc} and the short-circuit current I_{sc} . The short-circuit current is measured by shorting the output terminals, and measuring the terminal current under full

illumination. The maximum photo-voltage is produced under the open-circuit voltage. The open circuit voltage V_{oc} of the cell is obtained when the load current is zero, i.e., when $I = 0$.

Mathematical modeling of Environmental factors

The general equation describing the (I-V) characteristics of the PV cell is obtained from Eq.1 by ignoring the last term of the shunt resistance, and using the famous formula used for the diode current, as follows:

$$I = I_L - I_0(e^{q(V+IR_s)/nKT} - 1)$$

Where:

q = electron charge = 1.6×10^{-19} Coulombs.

n = ideality factor = 1 to 2.

K = Boltzmann constant = 1.38×10^{-23} Joule/K

T_r = rated cell temperature in Kelvin.

R_s = cell series resistance (ohm).

Effect of Variation in Cell Temperature [4]

The value of the saturation current I_0 at different operating temperatures is calculated as follow:

$$I_0 = I_0(T_r) * (T/T_r)^3 * e^{-qV_g/nk} * \{ 1 - T_r^{-1} T \} \quad I_0(T_r) = I_{SC}(T_r) / [e^{qV_{oc}(T_r)/nKT} - 1]$$

Where:

V_g = The band gap voltage

$V_{oc}(T_r)$ = Open Circuit voltage at rated operating conditions.

$I_{SC}(T_r)$ = Short circuit current at rated operating conditions.

T is operating temperature of the cell (K)

Effect of Solar Radiation Variation [4]

The photocurrent $I_L(A)$ is directly proportional to solar radiation level G (W/m^2), as follow:

$$I_L = I_L(T_r) (1 + \alpha I_{SC}(T - T_r)) \quad I_L(T_r) = G * I_{SC}(T_r, nom) / G_r \quad \alpha I_{SC} = dI_{SC}/dT$$

Where, αI_{SC} = the short circuit temperature coefficient (A/sec).

G is operating solar radiation level G_r is rated solar radiation level Now for an array containing N_S cells in series and such N_P strings in parallel. We can modify the diode current equations of the cell as presented below:

$$I_d = I_0(e^{q(V+IR_s)/nKT} - 1) \quad I_0 = I_0(T_r) * (T/T_r)^3 * e^{-qV_g/nk} * \{ 1 - T_r^{-1} T \} \quad I_0(T_r) = I_{SC}(T_r) / [e^{qV_{oc}(T_r)/nKT} - 1]$$

WIND TURBINE SYSTEM

Wind turbine is applied to convert the wind Energy to mechanical torque. The mechanical torque of turbine can be calculated from mechanical power at the turbine extracted from wind power. This fact of the wind speed after the turbine isn't zero. Then, the power coefficient of the turbine (C_p) is used. The power coefficient is function of pitch angle (β) and tip speed (λ), pitch angle is angle of turbine blade whereas tip speed is the ratio of rotational speed and wind speed. The power coefficient maximum of (C_p) is known as the limit of Betz. The power coefficient is given by

$$C_P(\lambda, \beta) = C_1 (C_2 \lambda_i - c_3 \beta - c_4) e^{-c_5 \lambda_i + c_6 \lambda}$$

$$1/\lambda_i = 1/\lambda + 0.08\beta - 0.035/\beta^3 + 1$$

The power coefficient is given by $c_p = p_m/p_w$; $c_p < 1$

$$p_m = c_p(\lambda, \beta) (\rho S / 2) v_w^3$$

Where

P_m = the mechanical output power of the turbine

C_p = the performance coefficient of the turbine

ρ = the air density

S = the turbine swept area

V_w = the wind speed K_p = gain power λ = the tip speed ratio

β = the blade pitch angle

The mechanical torque is given by $T_m = P_m / \omega$

The WECS is presented with two-mass drive train model. The mathematical model are given by [12]

$$2H_t \frac{d\omega_t}{dt} = T_m - T_s$$

$$1 / \omega_{st} \frac{d\theta_{sta}}{dt} = \omega_t - \omega_r$$

$$T_s = K_{ss} \theta_{sta} + D_t \frac{d\theta_{sta}}{dt}$$

Where

H_t = the inertia constant of the turbine

θ_{sta} = the shaft twist angle

ω_t = the angular speed of the wind turbine

ω_r = the rotor speed of generator webs = the electrical base speed

T_s = Shaft torque

K_{ss} = the shaft stiffness

D_t = the damping coefficient

Modelling Of Wind-PV Hybrid System in MATLAB / SIMULINK:

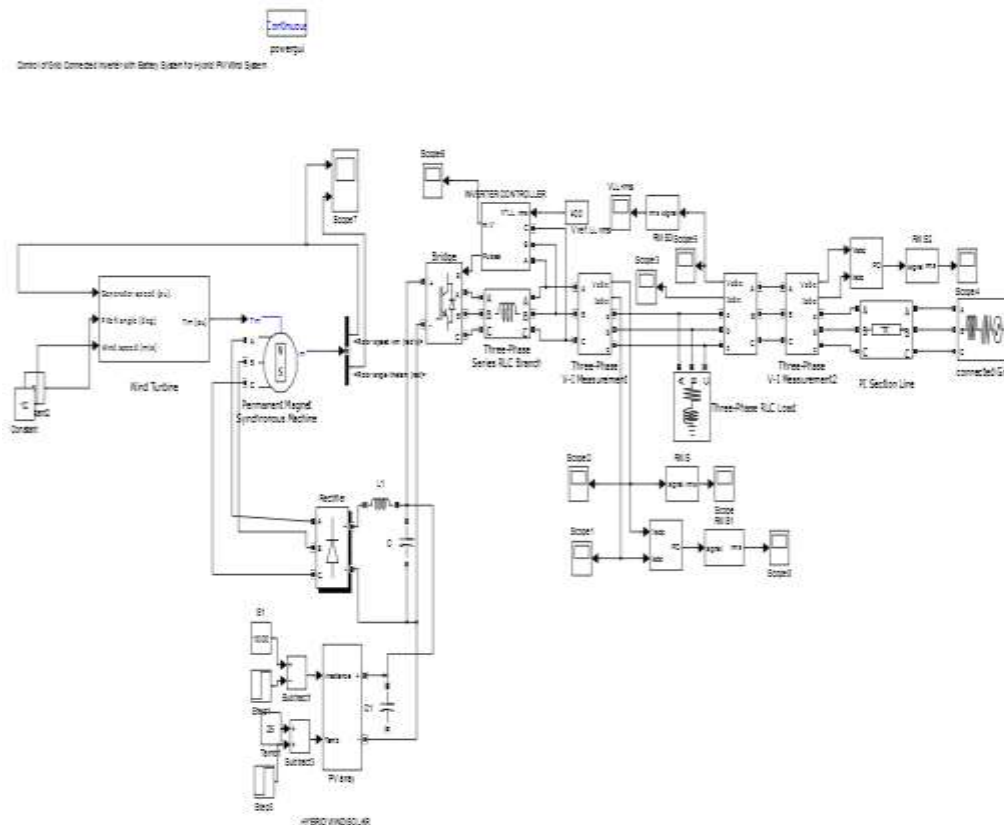

SIMULATION RESULT

The modeling of SAPS system (PV/Wind Hybrid) is done in MATLAB. The simulation is further done using Phase lock loop for synchronization of grid and PID controller is used for inverter control.

The parameters used for the proposed hybrid stand-alone power system are shown in table

Generator	Permanent Magnet Synchronous	
Number of pole pairs		4
Rated speed (rpm)		1260
Rated power (kw)		1
Stator resistance (ohm)		5.8
Direct inductance (mh)		0.045
Quadrature inductance (mh)		0.102
Inertia		0.011
Wind turbine		
Rated power (kW)		1.1
Base wind speed (m/s)		12
Series inductance (mh)		13
Shunt capacitance (micro F)		20
Solar cell		
Nominal voltage (volt)		24.23
Nominal current (amp)		52
Number of cell		42
Operating temperature (Oc)		55
Rated power (kW)		1.26

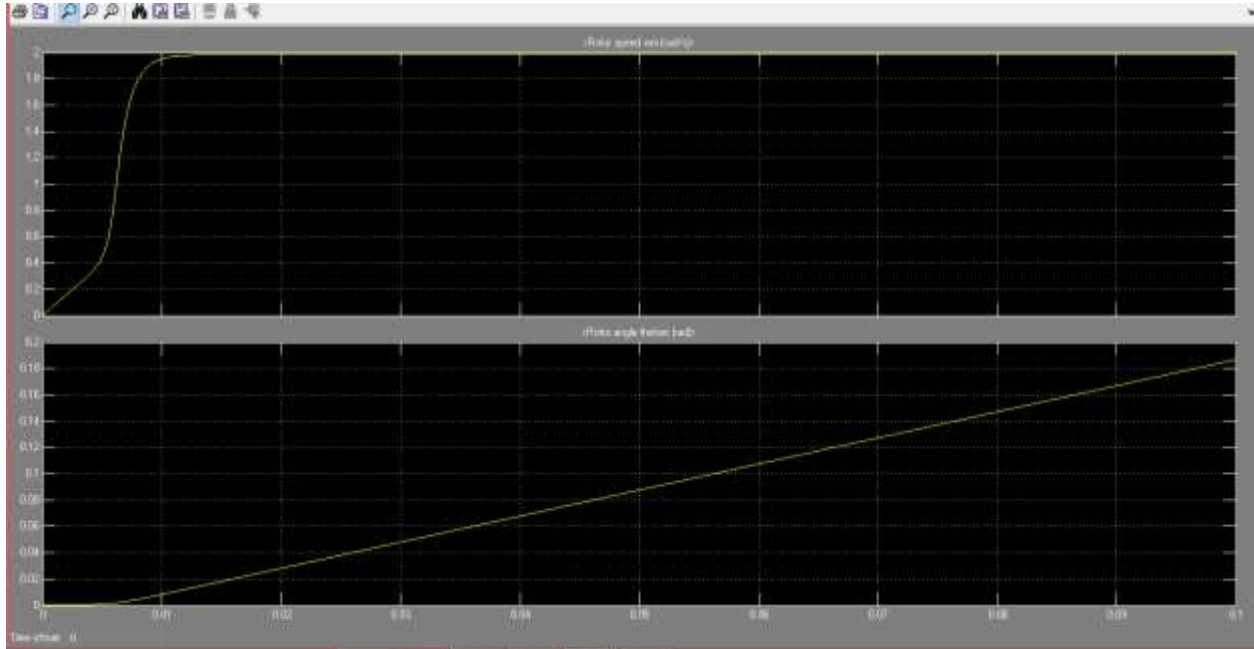

Waveform of Output voltage of SAPS system

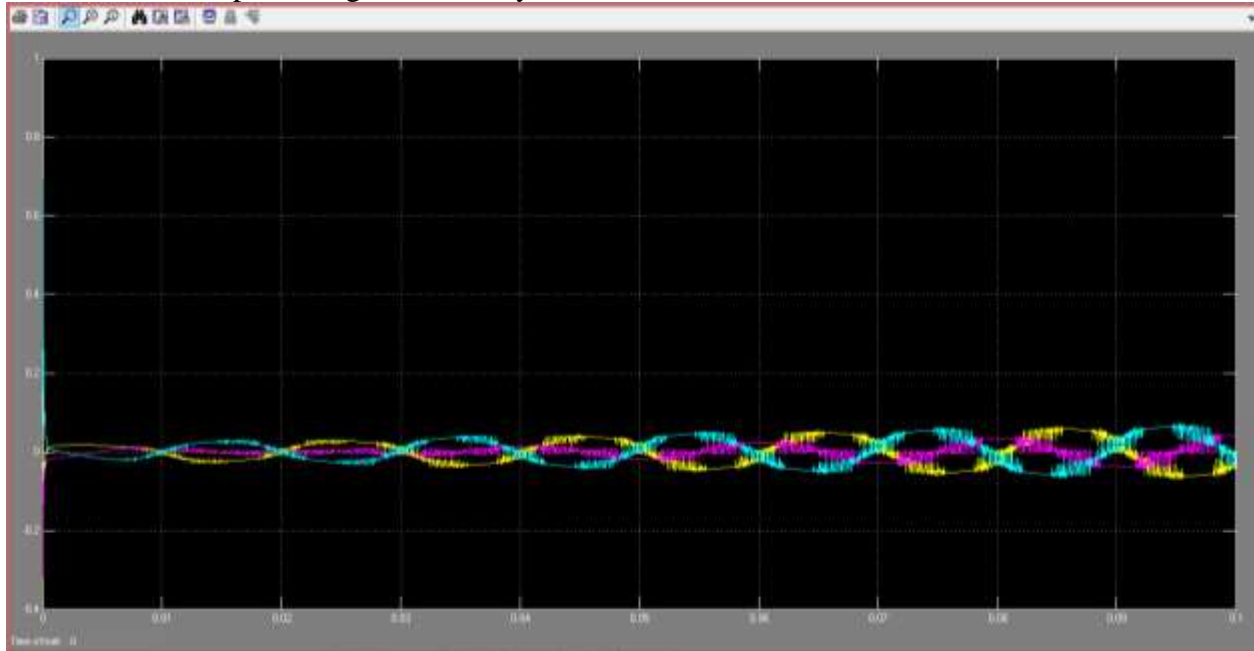

Waveform of output Current injected to grid side

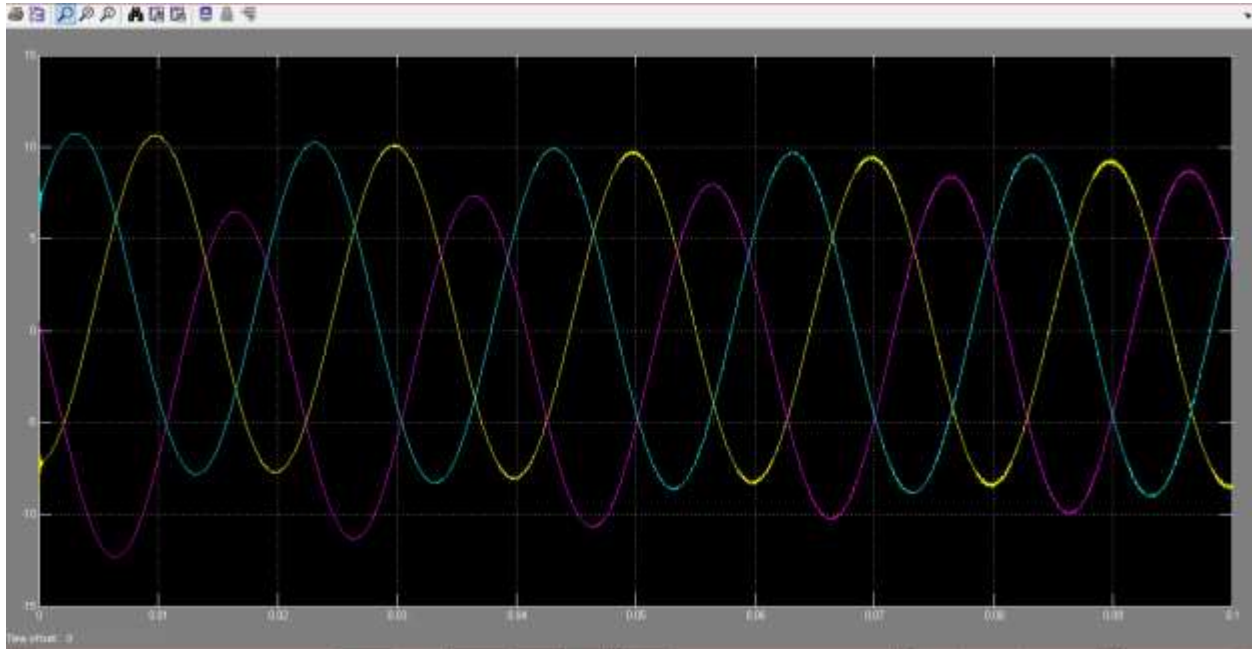

Waveform of output current injected to grid side

CONCLUSION

This paper presented the modeling, simulation and Control of a grid connected PV and Wind Hybrid Power System. The system is simulated in Matlab/Simulink environment. It is observed that the extraction of the maximum power from SPV array is obtained using MPPT system. The INC MPPT algorithm has been implemented. In Wind Energy Conversion system Permanent magnet synchronous generator based wind turbine used. The PV output and the wind output after converting to dc by the help of rectifier is given to the inverter and then the combination of PV and Wind is given to the grid.

References

1. S. Bose, Y. Liu, K. Bahei-Eldin, J.de Bedout, and M. Adamiak, "Tie line Controls in Microgrid Applications," in *iREP Symposium Bulk Power System Dynamics and Control VII, Revitalizing Operational Reliability*, pp. 1-9, Aug. 2007.
2. R. H. Lasseter, "MicroGrids," in *Proc. IEEE-PES'02*, pp. 305-308, 2002.
3. Michael Angelo Pedrasa and Ted Spooner, "A Survey of Techniques Used to Control Microgrid Generation and Storage during Island Operation," in *AUPEC*, 2006.
4. F. D. Kanellos, A. I. Tsouchnikas, and N. D. Hatziargyriou, "Microgrid Simulation during Grid-Connected and Islanded Mode of Operation," in *Int. Conf. Power Systems Transients (IPST'05)*, June. 2005.
5. Y. W. Li, D. M. Vilathgamuwa, and P. C. Loh, Design, analysis, and real-time testing of a controller for multi bus microgrid system, *IEEE Trans. Power Electron.*, vol. 19, pp. 1195-1204, Sep. 2004.
6. R. H. Lasseter and P. Paigi, "Microgrid: A conceptual solution," in *Proc. IEEE- PESC'04*, pp. 4285-4290, 2004.
7. F. Katiraei and M. R. Iravani, "Power Management Strategies for a Microgrid with Multiple Distributed Generation Units," *IEEE trans. Power System*, vol. 21, no. 4, Nov. 2006.

8. P. Piagi and R. H. Lasseter, "Autonomous control of microgrids," in *Proc. IEEE-PES'06*, 2006, *IEEE*, 2006.
9. M. Barnes, J. Kondoh, H. Asano, and J. Oyarzabal, "Real-World MicroGrids- an Overview," in *IEEE Int. Conf. Systems of Systems Engineering*, pp.1-8, 2007.
10. Chi Jin, Poh Chiang Loh, Peng Wang, Yang Mi, and Frede Blaabjerg, "Autonomous Operation of Hybrid AC-DC Microgrids," in *IEEE Int. Conf. Sustainable Energy Technologies*, pp. 1-7, 2010.
11. Y. Zoka, H. Sasaki, N.Yomo, K. Kawahara, C. C. Liu, "An Interaction Problem of Distributed Generators Installed in a MicroGrid," in *Proc. IEEE Elect. Utility Deregulation, Restructuring and Power Technologies*, pp. 795-799, Apr. 2004.
12. H. Nikkhajoei, R. H. Lasseter, "Microgrid Protection," in *IEEE Power Engineering Society General Meeting*, pp. 1-6, 2007.
13. Zhenhua Jiang, and Xunwei Yu, "Hybrid DC- and AC-Linked Microgrids: Towards Integration of Distributed Energy Resources," in *IEEE Energy2030 Conf.*, pp.1-8, 2008.
14. Bo Dong, Yongdong Li, ZhixueZheng, Lie Xu "Control Strategies of Microgrid with Hybrid DC and AC Buses," in *Power Electronics and Applications, EPE'11, 14thEuropean Conf.*, pp. 1-8, 2011.
15. Dong Bo, Yongdong Li , and Zedong Zheng, "Energy Management of Hybrid DC and AC Bus Linked Microgrid," in *IEEE Int. Symposium Power Electronics for Distributed Generation System*, pp. 713-716, 2010.
16. Xiong Liu, Peng Wang, and Poh Chiang Loh, "A Hybrid AC/DC Microgrid and Its Coordination Control," *IEEE Trans. Smart Grid*, vol. 2, no. 2, pp. 278-286 June. 2011.